

DATA SHEET, SERVICE & OPERATING MANUAL

B25

AIR OPERATED DOUBLE DIAPHRAGM PUMP 1A Metallic Series



Table of Contents

Service / Maintenance Log	2
Performance Curve	3
Dimensions.....	3
Engineering Data & Temperature limitations.....	4
Explanation of Pump Nomenclature.....	4
Principle of Pump Operation.....	5
Installation guide.....	5
Troubleshooting	6
Recycling.....	6
Important Safety Information.....	6
Warranty.....	7
Service.....	7
Air Valve Overhaul.....	7
Wet-side Overhaul.....	7
Parts List	8
Assembly Drawing.....	9
Declaration of Conformity	10

Service / Maintenance Log

Date	Details	Completed

Contact Information

Contact	Phone / Fax No.

BLAGDON PUMP

A Unit of IDEX Corporation

LAMBERT ROAD, ARMSTRONG, WASHINGTON,
TYNE & WEAR NE37 1QP
ENGLAND.
TEL. : (0191) 4177475 FAX. : (0191) 4175435
Web Site : www.blagdonpump.com
E-Mail : sales@blagdonpump.com

DATA SHEET, SERVICE & OPERATING MANUAL



B25

AIR OPERATED DOUBLE DIAPHRAGM PUMP 1A Metallic Series

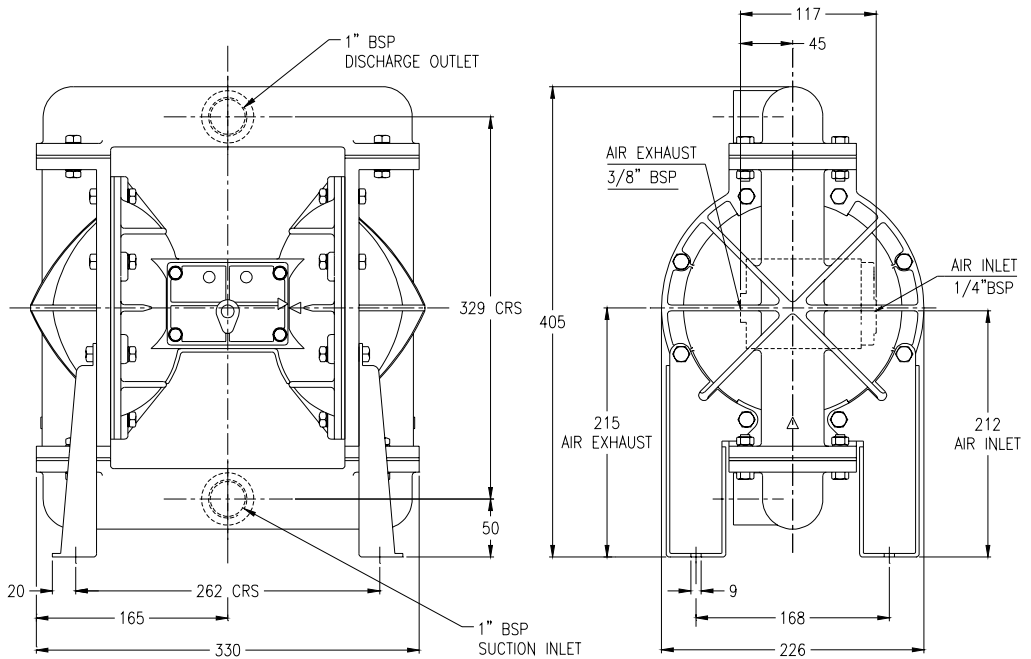

General Assembly :-
B25 1A Metallic pump
All dimensions +/- 3mm

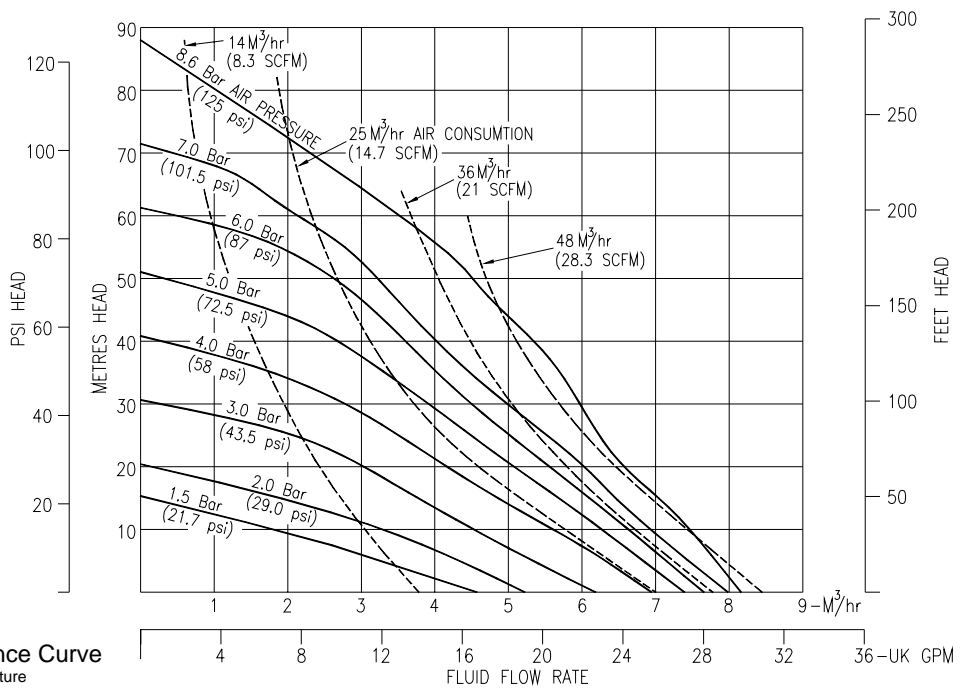

B25 1A Metallic Pump Performance Curve
Performance based on water at ambient temperature

TECHNICAL DATA				
FLUID CONNECTIONS 1" BSP (F)	CAPACITY 0 - 136 Liters/Minute (0 - 30 Gallons/Minute)	MAX SOLIDS 3 MM (1/8")	MAX DISCHARGE HEAD 88 Meters (289 ft)	DISPLACEMENT/STROKE 0.475 Litres (0.1 UK Gallons)
MAX. WORKING PRESSURE 8.6 Bar (125 psi)	AIR INLET 1/4" BSP (F)	TEMPERATURE LIMITS Determined by Elastomers		PUMP WEIGHTS :- AA :- 16.3 Kg CA :- 27.8 Kg SA :- 31.8 Kg CC :- 34.8 Kg SC :- 38.8 Kg SS :- 39.8 Kg

ⓘ Caution - Operating temperature limitations are as follows:

Materials	Operating Temperatures		
	Maximum	Minimum	Optimum
Buna-n - General purpose, oil resistant. Shows good solvent, oil, water and hydraulic fluid resistance. Should not be used with highly polar solvents like acetone and MEK, ozone, chlorinated hydrocarbons and nitro hydrocarbons.	176°F 80°C	-18°F -28°C	50° to 140°F 10° to 60°C
EPDM - Shows very good water and chemical resistance. Has poor resistance to oils and solvents, but is fair on ketones and alcohols.	212°F 100°C	-11°F -24°C	50° to 212°F 10° to 100°C
Neoprene - All purpose. Resistant to vegetable oil. Generally not affected by moderate chemicals, fats greases and many oils and solvents. Generally attacked by strong oxidising acids, ketones, esters, nitro hydro carbons and chlorinated aromatic hydrocarbons.	212°F 100°C	-4°F -20°C	50° to 130°F 10° to 54°C
Santoprene® - Injection moulded thermoplastic elastomer with no fabric layer. Long mechanical flex life. Excellent abrasion resistance.	212°F 100°C	-10°F -23°C	50° to 212°F 10° to 100°C
Virgin PTFE - Chemically inert, virtually impervious. Very few chemicals are known to react chemically with PTFE : molten alkali metals, turbulent liquid or gaseous fluorine and a few fluoro-chemicals such as chlorine trifluoride or oxygen difluoride which readily liberate free fluorine at elevated temperatures.	356°F 180°C	32°F 0°C	50° to 212°F 10° to 100°C
Viton® - Shows good resistance to a wide range of oils and solvents : especially all aliphatic, aromatic and halogenated hydrocarbons, acids, animal and vegetable oils.	356°F 180°C	0°F -18°C	75° to 212°F 24° to 100°C
Polypropylene - High strength, light weight, corrosion resistant polyolefin which easily withstands most chemicals, with no known solvent at room temperature.	158°F 70°C	-40°F -40°C	50° to 140°F 10° to 60°C

TYPICAL CODE = 1A. S A. B B. N N S

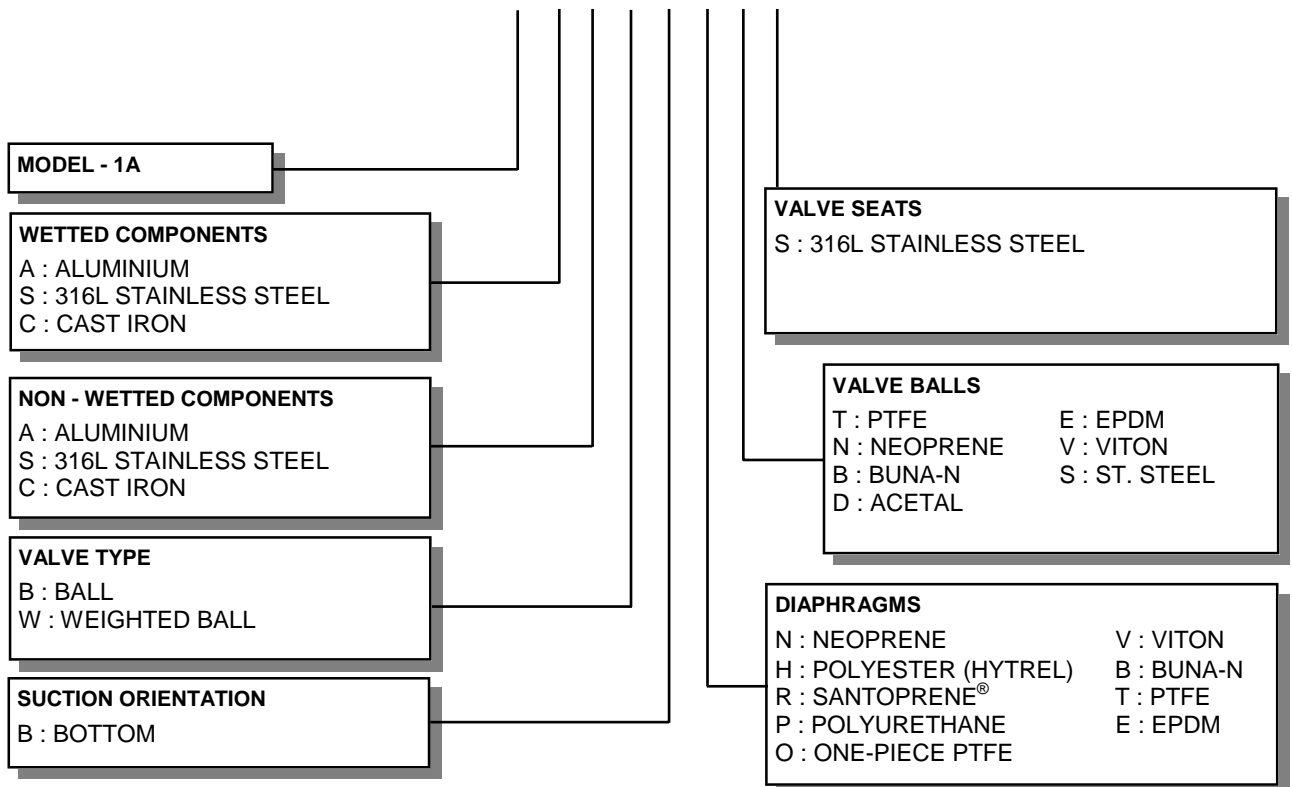

IMPORTANT

This pump should be used in accordance with the requirements of the Health and Safety at Work Act 1974.
All business conducted subject to Blagdon Pump. Terms and Conditions of Sale, available on request.

<p>BLAGDON PUMP A Unit of IDEX Corporation</p>	<p>LAMBERT ROAD, ARMSTRONG, WASHINGTON, TYNE & WEAR NE37 1QP ENGLAND. TEL. : (0191) 4177475 FAX. : (0191) 4175435 Web Site : www.blagdonpump.com E-Mail : sales@blagdonpump.com</p>
---	--

PRINCIPLE OF PUMP OPERATION

This ball valve type diaphragm pump is powered by compressed air and is a 1:1 ratio design. The inner side of one diaphragm chamber is alternately pressurised while simultaneously exhausting the other inner chamber. This causes the diaphragms, which are connected by a common shaft secured by plates to the centres of the diaphragms, to move in a reciprocating action. (As one diaphragm performs a discharge stroke the other diaphragm is pulled to perform the suction stroke in the opposite chamber.) Air pressure is applied over the entire inner surface of the diaphragm while liquid is discharged from the opposite side of the diaphragm. The diaphragm operates in a balanced condition during the discharge stroke which allows the pump to be operated at discharge heads of over 200 feet (61 meters) of water.

For maximum diaphragm life, keep the pump as close to the liquid being pumped as possible. Positive suction head in excess of 10 feet of liquid (3.048 meters) may require a back pressure regulating device to maximize diaphragm life.

Alternate pressurising and exhausting of the diaphragm chamber is performed by an internally mounted, pilot/distributor operated, 2 way type distribution valve. When the distributor spool shifts to one end of the valve block body, inlet pressure is applied to one chamber and the other diaphragm chamber exhausts. When the spool shifts to the opposite

end of the valve body, the pressure to the chambers is reversed. The air distribution valve spool is moved by an internal pilot spool which alternately pressurises one end of the air distribution valve spool while exhausting the other end. The pilot valve is shifted at each end of the diaphragm stroke when an actuator pin in the pilot spool is contacted by the diaphragm shaft. This then moves the pilot spool to redirect inlet pressure to the opposite end of the air distribution valve spool, which in-turn pressurises the opposite chamber.

The chambers are connected by manifolds with a suction and discharge ball valve for each chamber, maintaining flow in one direction through the pump.

INSTALLATION

The typical installation shown in FIG. 1 is only a guide to selecting and installing system components. Your installation will depend on the type of fluid being pumped and your application needs. To reduce the risk of serious bodily injury and damage to property, never use fluids in this pump which are not compatible with the wetted components. Contact your local distributor or the manufacturer for system design assistance & compatibility if necessary.

Mount the pump in an upright position. Failure to ensure an upright position may result in loss of or poor priming characteristics. Ensure the pump is securely mounted to avoid movement and possible risk of bodily injury.

PRESSURE The pump delivers the same

pressure at the discharge outlet as the air pressure applied at the air inlet (unless pump is configured as a 2:1 ratio model).

NOTE: *Pressure Regulator (H) should be installed where air supply could exceed 125 psi.*

SAFETY

Your **BLAGDON PUMP** is a high performance unit capable of achieving high outputs at high efficiencies. However, as is common with pneumatic equipment, the pump efficiencies is reliant upon the air being clean, dry and filtered. Failure to comply with these requirements may lead to loss of performance and reduced component life and in extreme cases, permanent damage to the pump.

To avoid leaks, ensure that all fluid connections are tight. The use of PTFE thread tape correctly applied should be used to ensure 100% leak proof connections. **Failure to ensure 100% sealability of the suction connection could adversely affect suction performance.**

If you are pumping hazardous fluids, or operating the pump in an enclosed area, it is essential that the exhaust from the pump is piped away to a safe location. When pumping hazardous fluids the above instructions must be adhered to in order to ensure safe operating procedures. (Under certain operating conditions the failure of internal components can lead to the pumped fluid being exhausted via the pump exhaust outlet).

WARNING

NEVER place your hands over or near the pump suction inlet. Powerful suction could cause serious bodily injury.

FLUSH THE PUMP This pump was tested with water containing an oil-based rust inhibitor. If this solution could contaminate or react with the fluid you are pumping, flush the pump thoroughly with a solvent/detergent to clean internal components. The solvent/detergent must be compatible with the pump materials of construction. Care should be taken to flush the pump each time it is disassembled for maintenance or repair.

CAUTION

All **BLAGDON PUMPS** are built lubricated with grease during assembly and need no further lubrication. If the use of oil cannot be avoided, this will not present any problems. A light No. 2 class lithium grease is recommended. Other grades may cause the Air Logic System to operate intermittently, thereby causing a loss of output and failure to operate. Other seals are available for "clean room" conditions

If the pump accelerates or is running too fast due to a lack of fluid, then stop it immediately by shutting off the air supply. A dry pump will accelerate to a high speed causing wear to elastomers.

If the fluid you are pumping tends to dry up or set when it is not moving, then flush the pump as often as necessary to prevent the fluid from drying in the pump. Drain the pump thoroughly before storing.

If feasible, invert pump to allow any fluid to drain from the non-return valves.

Available from
Blagdon Pump

- ① Pulsation Dampener
- ② Lubricator
- ③ Filter/Regulator
- ④ Air Dryer

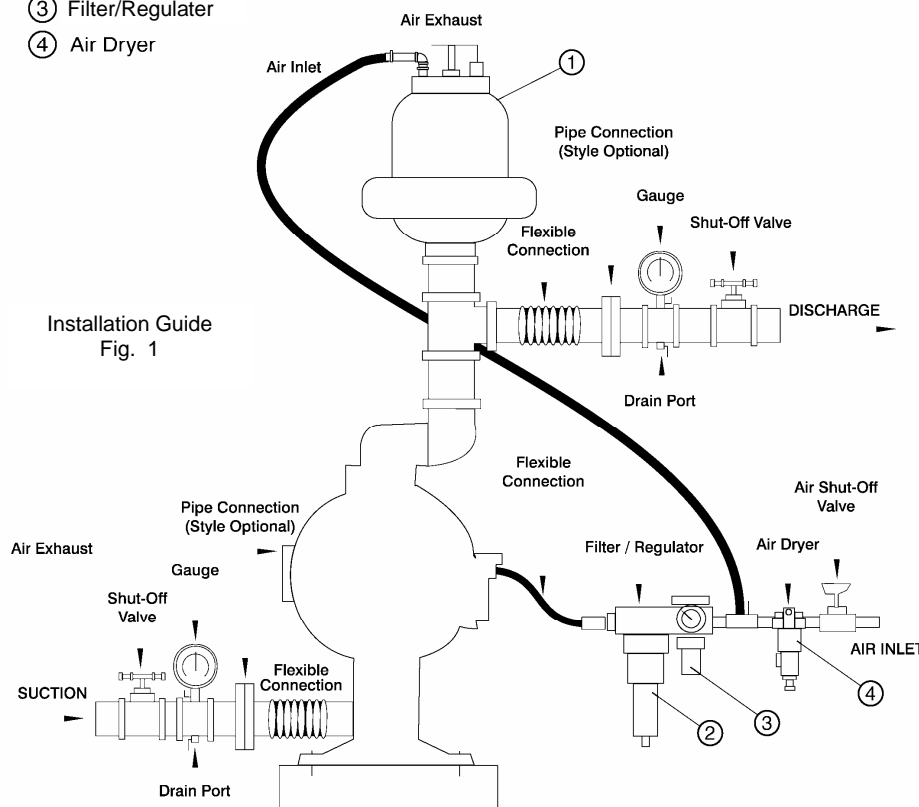
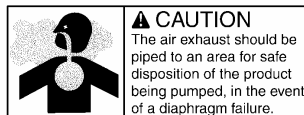

TROUBLE SHOOTING GUIDE

NOTE :- Check all solutions before dismantling the pump.

PROBLEM	CAUSE	SOLUTION
Pump will not start	Air valve assembly malfunction/Siezure Obstructed fluid line. Obstructed diaphragm chamber. Diaphragm failure causing fluid & excessive air to be expelled through the exhaust. Diaphragm seal failure. Air valve system malfunction. Air connected to exhaust.	Check carrier for freedom of movement. - Clean, oil & replace. Clean line or increase line size. Remove obstruction. Replace diaphragm. Replace shaft seals. Check all seals in valve chest assembly. Re-connect to air inlet.
Erratic flow	Diaphragm failure on one side. Valve ball not seating. Suction leakage. Diaphragm failure causing fluid & excessive air to be expelled through the exhaust. Diaphragm seal failure. Air valve system malfunction.	Replace diaphragm. Check and remove obstruction. Check and correct. Replace diaphragm. Replace shaft seals. Check all seals in valve chest assembly.
Pump strokes but will not discharge	Excessive suction lift. Suction line leakage. Valve ball not seating correctly or damaged. Suction line or strainer clogged. Diaphragm failure.	Shorten suction line. Check and correct. Check and remove obstruction / replace. Clear. Replace diaphragm.
Fluid discharged from air exhaust	Diaphragm Failure. Loose frontplate.	Replace diaphragm. Re-Torque to manual specifications.
Intermittent stroke rate	Over lubrication Diaphragm shaft seal failure. Air valve system malfunction. Valve ball not seating / partially obstructed.	Shut-down pump. Remove air connection into pump & introduce a small quantity of degreasing agent into air valve and replace line. Run pump until clear. Replace seals. Check all seals in valve chest assembly. Clear obstruction.



WARNING!

Read these safety warnings and instructions in this manual completely, before installation and start-up of the pump. It is the responsibility of the purchaser to retain this manual for reference. Failure to comply with the recommendations stated in this manual will damage the pump, and void factory warranty.



WARNING!

Before maintenance or repair, shut off the compressed air line, bleed the pressure, and disconnect the air line from the pump. The discharge line may be pressurized and must be bled of its pressure.



WARNING!

In the event of diaphragm rupture, pumped material may enter the air end of the pump, and be discharged into the atmosphere. If pumping a product which is hazardous or toxic, the air exhaust must be piped to an appropriate area for safe disposition.



WARNING!

Before doing any maintenance on the pump, be certain all pressure is completely vented from the pump, suction, discharge, piping, and all other openings and connections. Be certain the air supply is locked out or made non-operational, so that it cannot be started while work is being done on the pump. Be certain that approved eye protection and protective clothing are worn all times in the vicinity of the pump. Failure to follow these recommendations may result in serious injury or death.



WARNING!

Take action to prevent static sparking. Fire or explosion can result, especially when handling flammable liquids. The pump, piping, valves, containers or other miscellaneous equipment must be grounded.



CAUTION!

Before pump operation, inspect all gasketed fasteners for looseness caused by gasket creep. Re-torque loose fasteners to prevent leakage. Follow recommended torques stated in this manual.



IMPORTANT!

This pump is pressurized internally with air pressure during operation. Always make certain that all bolting is in good condition and that all of the correct bolting is reinstalled during assembly.



RECYCLING

Many components of BLAGDON air operated double diaphragm pumps are made of recyclable materials. We encourage pump users to recycle worn out parts and pumps whenever possible, after any hazardous pumped fluids are thoroughly flushed.



WARNING!

Airborne particles and loud noise hazards. Wear ear and eye protection.



WARNING!

When used for toxic or aggressive fluids, the pump should always be flushed clean prior to disassembly.



IMPORTANT!

Read these instructions completely, before installation and start-up. It is the responsibility of the purchaser to retain this manual for reference. Failure to comply with the recommendations stated in this manual will damage the pump, and void factory warranty.

SERVICE

The following sections give a general overview on how to service all models of BLAGDON Diaphragm Pumps. For details on individual part numbers, quantities, materials, etc., please consult the parts list supplied with the pump.

NOTE : *Before commencing any service or maintenance work on the pump, ensure that the air supply has been disconnected or isolated.*

AIR VALVE SYSTEMS

MECHANICAL TYPE - (1A Metallic)

Remove the 4 bolts securing the air inlet plate to the center section and withdraw the air valve assembly. A flat screwdriver can be inserted between the air inlet plate and the center section to "lever out" the assembly.

Remove both valve caps from the assembly.

Dismantle the valve block assembly by removing the M6 and M4 cap screws. Using a plastic mallet, gently tap the assembly to loosen, then remove gaskets, slide valve and valve carrier together with valve block and slide valve plate.

Using a flat screwdriver, remove the actuator pin from the pilot valve and withdraw valve from the valve block bore.

Clean all parts thoroughly and inspect for wear or damage. If the pilot valve bore is scored, or has worn excessively, the valve block must be replaced. Ensure any remaining thread sealant is removed from the pilot valve and actuator pin prior to re-assembly. Check valve carrier 'O' Rings for wear and replace as required.

Lubricate all parts with light oil before re-assembly.

Slide the pilot valve spool in its bore. Apply a drop of loctite - grade 222 (or equivalent locking compound), to the threads of the actuator pin and screw into the pilot valve spool, finger tight. Remove any excess locking compound

immediately and ensure freedom of movement within the bore.

Locate the valve carrier into the valve block so that the recess in the spool faces the rectangular opening in the valve block.

Re-assemble the remaining components, ensuring the assembled faces are flat so that an adequate seal is obtained.

Before final assembly into the center section, lightly grease both valve caps to ease assembly. Locate the actuator pin so that it will engage into the 'cut-out' area of the diaphragm shaft. (See fig 2) In addition, roughly align the 'arrow' on the air inlet plate with the arrow on the center section.

Re-assemble the air valve assembly into the center section and re-torque in accordance to the settings shown in the parts list.

In the event of a complete air-side overhaul, the valve block assembly must first be removed from the center section.

Failure to remove the valve block may result in component damage later in the dis-assembly procedure.

The pump should then be dis-assembled down to the center section assembly as described later in the "Wet-Side Overhaul".

Inspect the diaphragm shaft, shaft seals and bushes for wear or damage. Replace as needed. If bushes are replaced, they will require reaming in-line to dia 19.07 – 19.09 mm. Ensure shaft seals are replaced with the seal lips outermost.

Lubricate all relevant components and re-assemble as detailed above, in reverse order. Ensure the correct position of all components as detailed in all sectional assembly drawings.

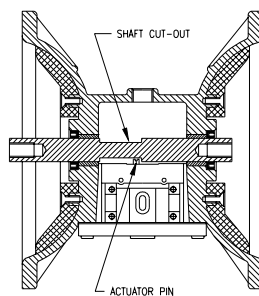

Fig. 2

OVERHAUL

WET-SIDE

REPLACING BALL VALVES

Remove discharge manifold from pump assembly together with associated valve balls, seats and 'O' rings.

NOTE :- *The orientation of the valve seat relative to the valve ball should be noted as incorrect positioning may result in a performance loss.*

Turn pump through 180° and remove the suction manifold. Clean and inspect the

components. Check for any wear or damage and replace as required.

NOTE :- *Ball or valve seat wear may result in loss of performance and suction lift.*

Re-assemble the valve balls/seats and ensure manifolds are adequately torqued to the settings shown in the parts list.

REPLACING DIAPHRAGMS

Remove both suction and discharge manifolds as detailed in the previous section, removing all ball valves, seats and 'O' rings.

Loosen and remove both outer covers from the pump assembly. The orientation of the covers should be noted so as to facilitate re-assembly.

Holding one of the frontplates in a vice, ('soft jaws' should be fitted), or with an adjustable spanner, loosen and remove the frontplate from the opposite end. Remove the diaphragm, backplate and bumpstop from diaphragm shaft.

Carefully withdraw the diaphragm shaft from the centre section and hold the free end in a vice, holding between the flats machined on the end. Loosen and remove the frontplate and remove the diaphragm together with backplate and bumpstop (where fitted).

NOTE :- *Care should be taken with all plastic, coated and hygienic pumps, so that the surface of the frontplate is not damaged.*

Thoroughly clean all parts and check for wear, damage, swelling, cracking, delamination and chemical attack.

Replace components where required.

NOTE :- *Rubber diaphragms should be replaced if they are worn to such an extent that the fabric re-enforcing is evident on the surface of the diaphragm.*

For pumps fitted with PTFE diaphragms, a light coating of grease should be applied to the back-up diaphragm prior to re-assembly.

Before re-assembly, it is advisable to check the condition of the diaphragm shaft seal/'O' rings for wear or attack. If either is evident, it is recommended that they be replaced.

Assemble the diaphragms onto the shaft in a reverse sequence to their removal. Care should be taken as to the orientation of the diaphragm relative to the front and back plates. All diaphragms have "AIR SIDE" molded onto one side. The backplate must be fitted adjacent to the

PARTS LIST

PART NUMBER WETTED COMPONENTS						
Ref No.	Cast Iron	Stainless Steel	Aluminium	Common Parts	Description	Qty
1	1A074	1A036	1A015		SUCTION MANIFOLD	1
2				SEE TABLE	O-RING ◆	8
3	** HEAVY DUTY OPTION - 1A205 **			1A004	VALVE SEAT	4
4	1A075	1A035	1A005		OUTER COVER	2
5	SA10104	SA10104	SA10502		FRONTPLATE ASSEMBLY	2
6				SEE TABLE	DIAPHRAGM ◆	2
7	1A007	1A259	1A007		BACKPLATE	2
8				SEE TABLE	VALVE BALL ◆	4
9	1A073	1A077	1A053		DISCHARGE MANIFOLD	1
10	1A076	1A037	SA10053		CENTRE SECTION	1
11				1A009	BUMPSTOP	2
12				1A010	DIAPHRAGM SHAFT SEAL	2
13				1A011	DIAPHRAGM SHAFT BUSH	2
14				1A008	DIAPHRAGM SHAFT	1
15				1A030	VALVE CAP - LH ● □	1
16				G122	O-RING ● □	2
17				1A024	VALVE SPOOL ●	1
18				1A025	SLIDE VALVE ●	1
19						
20				1A031	VALVE CAP - RH ● □	1
21		A180		A005	BOLT - M8 x 35	16
22		C193		C004	WASHER - M8	32
23		B179		B003	NUT - M8	24
24				SA10004	SILENCER	1
25		A181		A006	BOLT - M8 x 40	8
26		1A226		1A018	BASE LEG - LH	2
27		1A225		1A019	BASE LEG - RH	2
28				1A020	ACTUATOR PIN ●	1
29				1A021	PILOT VALVE SPOOL ●	1
30				1A026	GASKET (SLIDE VALVE PLATE) ● □	1
31				1A029	SLIDE VALVE PLATE ●	1
32				D009	SKT CAP SCREW - M4 x 20 ●	4
33				1A028	GASKET (AIR INLET PLATE) □	1
34	1A069	1A069	1A027		AIR INLET PLATE	1
35				1A023	VALVE BLOCK ●	1
36				D010	SKT CAP SCREW - M6 x 35	3
38		A182		A008	BOLT - M6 x 20	4
39		C183		C007	WASHER - M6	4

PARTS LIST - cont.

PUMPS FITTED WITH PTFE DIAPHRAGMS			
REF No.	PART NUMBER	DESCRIPTION	QTY
40	1A089	DIAPHRAGM - (BACK-UP) ◆	2
41	1A071	DIAPHRAGM - (PTFE) ◆	2

ELASTOMER TABLE								
REF No.	DESCRIPTION	BUNA-N	EPDM	VITON	NEOPRENE	ONE-PIECE PTFE	ST. STEEL	QTY
2	O-RING - (VALVE SEAT)	G057	G060	G061	G059	-	-	8
6	DIAPHRAGM	1A006	1A040	1A039	1A057	1A348	-	2
8	VALVE BALL	1A049	1A080	1A081	1A079	-	1A197	4
8	VALVE BALL - (WEIGHTED)	1A072	1A092	1A093	1A091	-	-	4

ELASTOMER TABLE - cont.							
REF No.	DESCRIPTION	PTFE	POLYESTER	SANTOPRENE®	DELIRIN (ACETAL)	POLYURETHANE	QTY
2	O-RING - (VALVE SEAT)	G058	-	-	-	-	8
6	DIAPHRAGM	SEE TABLE	1A061	1A358	-	1A070	2
8	VALVE BALL	1A002	-	-	1A050	-	4
8	VALVE BALL - (WEIGHTED)	-	-	-	-	-	4

◆ - These items are available in a recommended spares kit. Please refer to your local stockist / distributor for details.

□ - These items are available in a recommended spares kit - SA10102 - Air side Kit - (All models).

● - These items are available as a sub-assembly kit - SA10011S - Valve Block Assembly.

Santoprene is a registered tradename of Monsanto Corp.

NOTES :

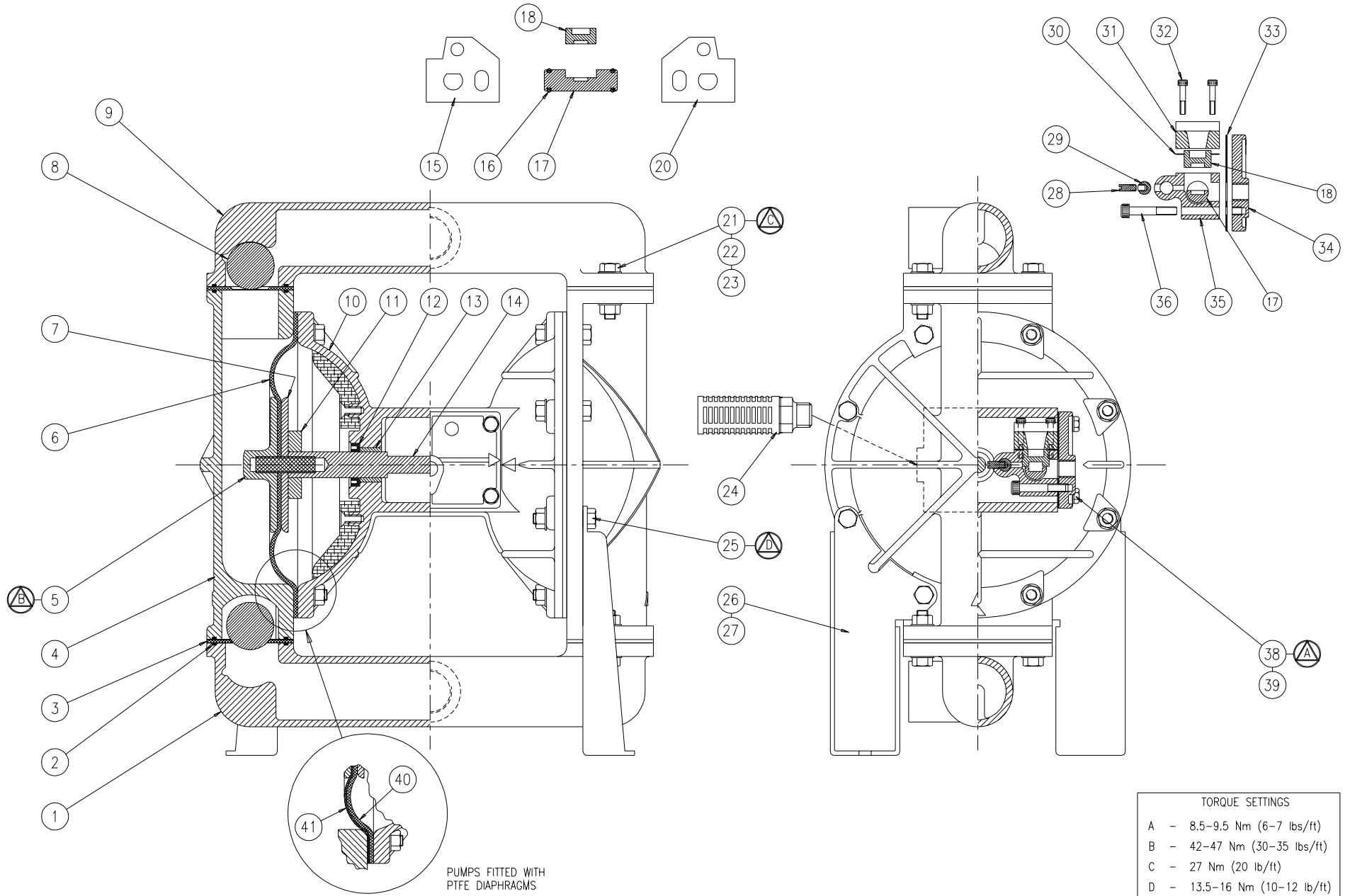

TORQUE SETTINGS	
A	- 8.5-9.5 Nm (6-7 lbs/ft)
B	- 42-47 Nm (30-35 lbs/ft)
C	- 27 Nm (20 lb/ft)
D	- 13.5-16 Nm (10-12 lb/ft)

Sectional General Assembly :- B25 1A Metallic Pump
Refer to page 8 Parts List table for item Ref. Nos.

Declaration of Conformity

DECLARATION DE CONFORMITE • DECLARACION DE CONFORMIDAD • ERKLÄRUNG BEZÜGLICH EINHALTUNG DER VORSCHRIFTEN •
DICHIARAZIONE DI CONFORMITÀ • CONFORMITEITSVERKLARING • DEKLARATION OM ÖVERENSSTÄMMELSE •
EF-OVERENSSTÄMMELSESERKLÄRING • VAATIMUSTENMUKAISUUSVAKUUTUS • SAMSVARSERKLÄRING • DECLARAÇÃO DE CONFORMIDADE •
Δήλωση Συμμόρφωσης

MANUFACTURED BY:

FABRIQUE PAR:
FABRICADA POR:
HERGESTELLT VON:
FABBRICATO DA:
VERVAARDIGD DOOR:
TILLVERKAD AV:
FABRIKANT:
VALMISTAJA:
PRODUSENT:
FABRICANTE:
Κατασκευαστής:

BLAGDON PUMP

A Unit of IDEX Corporation

Lambert Road, Armstrong,
Washington, Tyne & Wear.
NE37 1QP, England.
Tel. +44 (0) 191 4177475
Fax. +44 (0) 191 4175435



PUMP

MODEL, TYPE

MODELE, TYPE
MODELO, TIPO
MODELL, TYPE:
MODELLO, TIPO
MALLI, TYYPI:
ΜΟΝΤΕΛΟ, ΤΥΠΟΣ:

SERIAL NO.:

NO. SERIE:
NO. DE SERIE:
SERIEN-NR.:
NUMERI DI SERIE
SERIENUMMERS:
TILLVERKNINGS NUMMER:
SERIENR.:
SARJA NO.:
SERIE NR.:
ΑΡ. ΣΕΙΡΑΣ:

This product complies with the following European Community Directives:

Ce produit est conforme aux directives de la Communauté européenne suivantes:

Este producto cumple con las siguientes Directrices de la Comunidad Europea:

Dieses produkt erfüllt die folgenden Vorschriften der Europäischen Gemeinschaft:

Questo prodotto è conforme alle seguenti direttive CEE:

Dir produkt voldoet aan de volgende EG-richtlijnen:

Denna produkt överensstämmer med följande EU direktiv:

Blagdon Pump, erklærer herved som fabrikant, at ovennævnte produkt er

i overensstemmelse med bestemmelserne i Direktive:

Tämä tuote täyttää seuraavien EC Direktiivien vaatimukset:

Dette produkt oppfyller kravene til følgende EC Direktiver:

Este produto está de acordo com as seguintes Directivas comunitárias:

Το παρόν προϊόν πληροί τις εξής οδηγίες της ΕΕ:

98 / 37 / EC

This product has used the following harmonized standards to verify conformance:

Ce matériel est fabriqué selon les normes harmonisées suivantes, afin d' en garantir la conformité:

Este producto cumple con las siguientes directrices de la comunidad europea:

Dieses produkt ist nach folgenden harmonisierten standards gefertigt worden, die übereinstimmung wird bestätigt:

Questo prodotto ha utilizzato i seguenti standards per verificare la conformità:

De volgende geharmoniseerde normen werden gehanteerd om de conformiteit van dit produkt te garanderen:

För denna produkt har följande harmoniserande standarder använts för att bekräfta överensstämmelse:

Harmoniserede standarder, der er benyttet:

Tässä tuotteessa on sovellettu seuraavia yhdenmukaistettuja standardeja:

Dette produkt er produsert i overensstemmelse med følgende harmoniserte standarder:

Este produto utilizou os seguintes padrões harmonizados para verificar conformidade:

Το παρόν προϊόν χρησιμοποιεί τα ακόλουθα μέτρα και σταθμά εναρμονισμού για την επιβεβαίωση της συμμόρφωσης:

EN 809

AUTHORIZED / APPROVED BY:

Approuve par:
Aprobado por:
Genehmigt von:
approvato da:
Goedgekeurd door:

Underskrift:
Valtuutettuna:
Bemyndiget av:
Autorizado Por:
Εγκριθηκε απο:

Jeff Sill,
General Manager

DATE: December 15, 2000

FECHA:
DATUM:
DATA:
DATO:
PÄIVÄYS:
Ημερομηνία:



HG-CF-223 (REV 4)