

# BLAGDON

## B25 & X25

AIR OPERATED DOUBLE DIAPHRAGM PUMP

1" Full Flow 2:1 Series

### B25

### DIMENSIONS

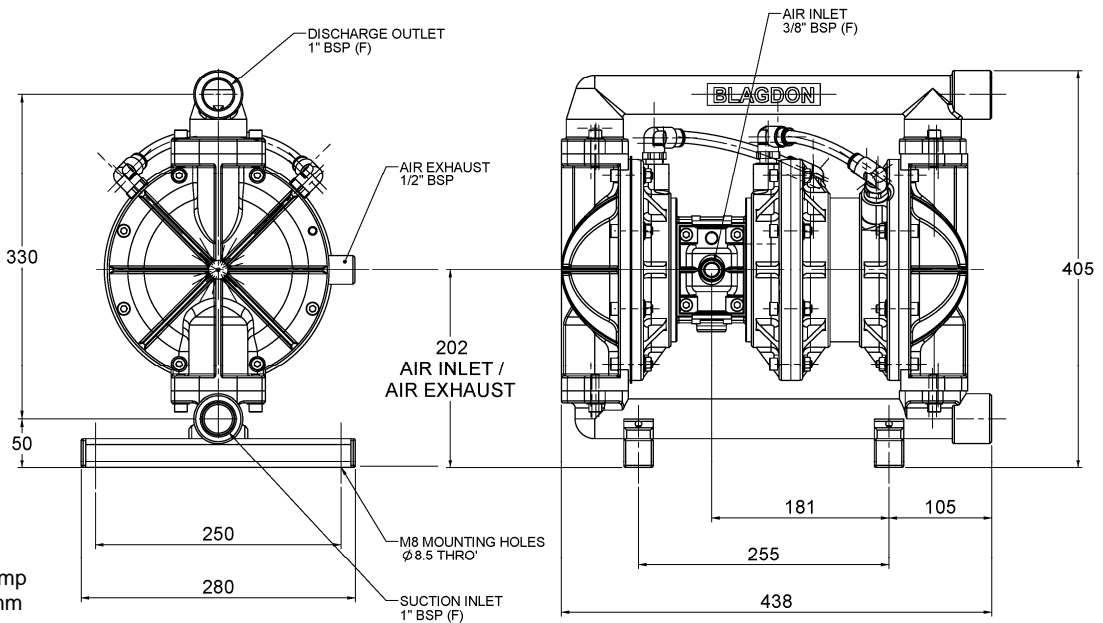

General Assembly :-  
B25 Full Flow 2:1 Pump  
All dimensions +/- 2mm

### B25

### PERFORMANCE

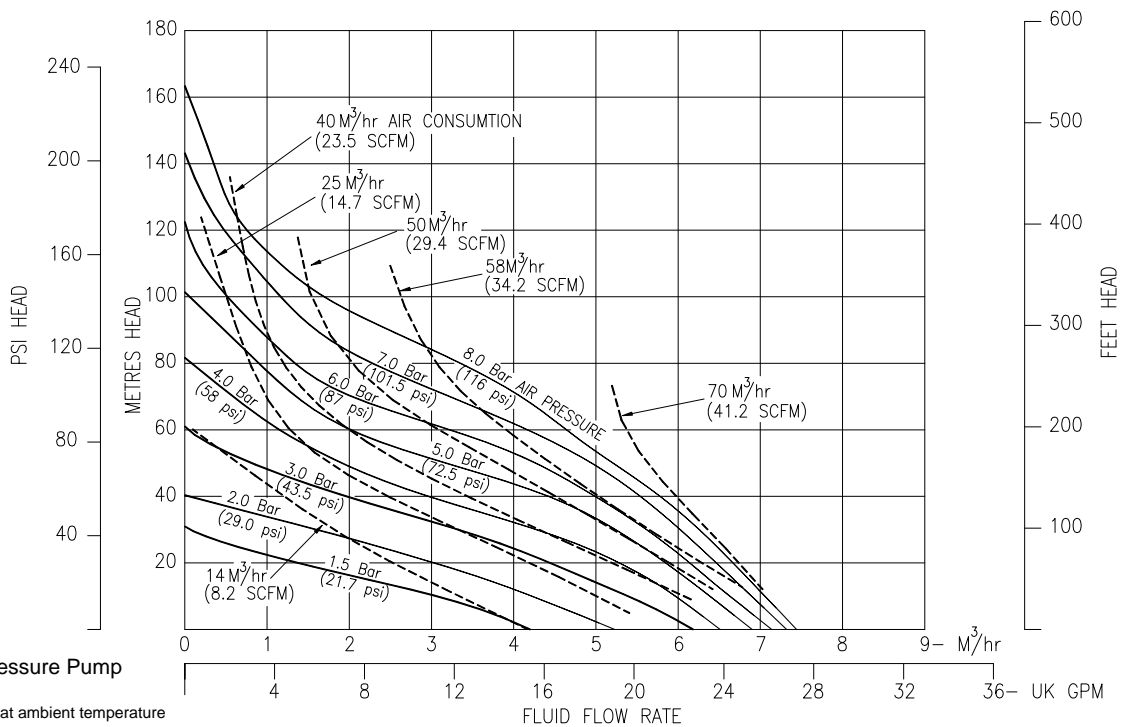

B25 Full Flow High Pressure Pump  
Performance Curve  
Performance based on water at ambient temperature

|  |  |   |  |   |
|--|--|---|--|---|
| <b>FLUID CONNECTIONS</b><br>1" BSP (F)                                       | <b>CAPACITY</b><br>0 - 125 Litres/Minute<br>(0 - 27.5 UK Gallons/Minute) | <b>MAX SOLIDS</b><br>3 MM<br>(1/8")                   | <b>MAX DISCHARGE HEAD</b><br>163 Meters<br>(536 ft)                          | <b>DISPLACEMENT/<br/>STROKE</b><br>0.475 Liters<br>(0.11 UK Gallons)    |
| <b>MAX. WORKING PRESSURE</b><br>16.0 Bar (232 psi)<br>(8 Bar max. air inlet) | <b>AIR INLET</b><br>3/8" BSP (F)   | <b>TEMPERATURE LIMITS</b><br>Determined by Elastomers | <b>SUCTION LIFT - DRY:</b> 6 M(20')<br><b>SUCTION LIFT - WET:</b> 7.6 M(25') | <b>PUMP WEIGHTS :-</b><br>AA :- 25.5 Kg<br>SA :- 34.5 Kg    SS :- 53 Kg |

**ⓘ Caution - Operating temperature limitations are as follows:**

Operating Temperatures

**Materials**

Maximum                      Minimum                      Optimum

|   |                |                |                              |
|---|----------------|----------------|------------------------------|
| <b>Buna-n</b> - General purpose, oil resistant. Shows good solvent, oil, water and hydraulic fluid resistance. Should not be used with highly polar solvents like acetone and MEK, ozone, chlorinated hydrocarbons and nitro hydrocarbons.  | 176°F<br>80°C  | -18°F<br>-28°C | 50° to 140°F<br>10° to 60°C  |
| <b>EPDM</b> - Shows very good water and chemical resistance. Has poor resistance to oils and solvents, but is fair on ketones and alcohols.   | 212°F<br>100°C | -11°F<br>-24°C | 50° to 212°F<br>10° to 100°C |
| <b>Neoprene</b> - All purpose. Resistant to vegetable oil. Generally not affected by moderate chemicals, fats greases and many oils and solvents. Generally attacked by strong oxidising acids, ketones, esters, nitro hydro carbons and chlorinated aromatic hydrocarbons.   | 212°F<br>100°C | -4°F<br>-20°C  | 50° to 130°F<br>10° to 54°C  |
| <b>Santoprene®</b> - Injection moulded thermoplastic elastomer with no fabric layer. Long mechanical flex life. Excellent abrasion resistance.  | 212°F<br>100°C | -10°F<br>-23°C | 50° to 212°F<br>10° to 100°C |
| <b>PTFE</b> - Chemically inert, virtually impervious. Very few chemicals are known to react chemically with PTFE : molten alkali metals, turbulent liquid or gaseous fluorine and a few fluoro-chemicals such as chlorine trifluoride or oxygen difluoride which readily liberate free fluorine at elevated temperatures. | 356°F<br>180°C | 32°F<br>0°C    | 50° to 212°F<br>10° to 100°C |
| <b>Viton®</b> - Shows good resistance to a wide range of oils and solvents : especially all aliphatic, aromatic and halogenated hydrocarbons, acids, animal and vegetable oils.   | 356°F<br>180°C | 0°F<br>-18°C   | 75° to 212°F<br>24° to 100°C |
| <b>Polypropylene</b> - High strength, light weight, corrosion resistant polyolefin which easily withstands most chemicals, with no known solvent at room temperature.   | 158°F<br>70°C  | -40°F<br>-40°C | 50° to 140°F<br>10° to 60°C  |

**TYPICAL CODE = B25.05.A A.W 3. N N S**

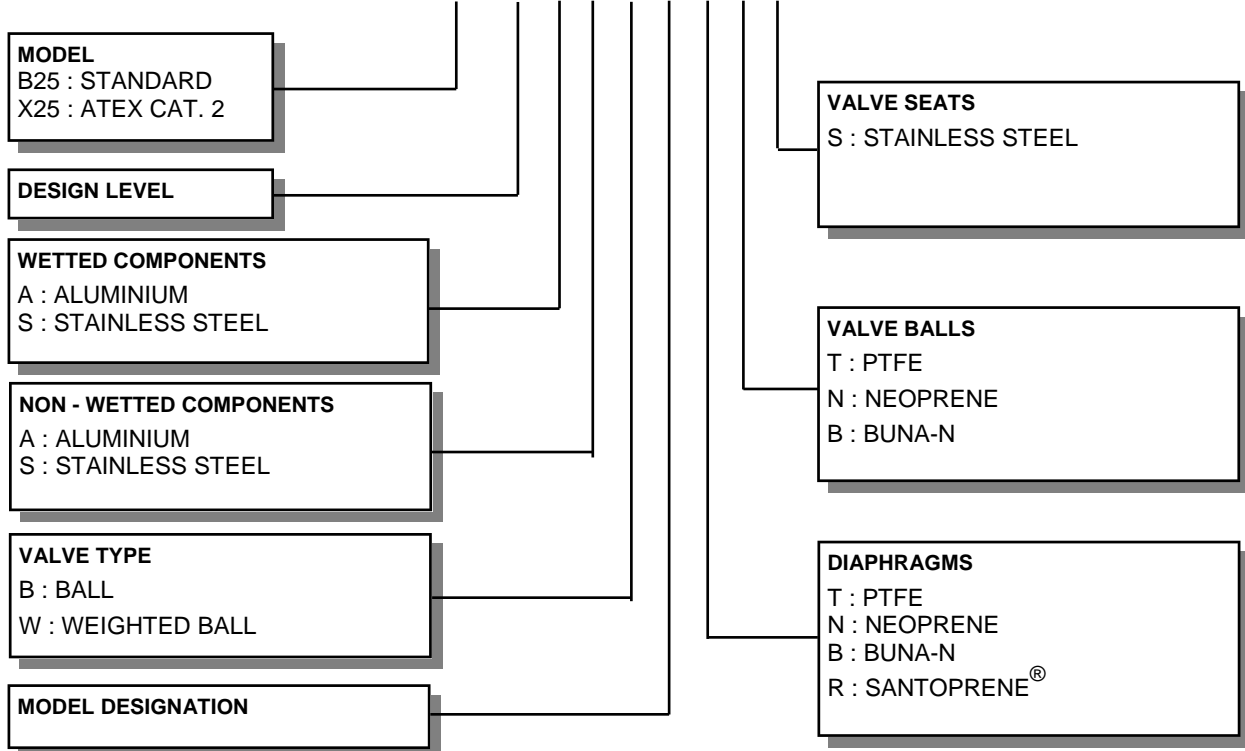

**IMPORTANT**

This pump should be used in accordance with the requirements of the Safety, Health & Welfare at Work Act 2005. All business conducted subject to IDEX Pump Technologies, Ireland. Terms and Conditions of Sale, available on request.



IDEX Pump Technologies (Ireland) Ltd.,  
A Unit of IDEX Corporation,  
R79, Shannon, Co Clare, IRELAND.  
TEL : +353 61 471933    FAX : +353 61 475046  
Web Site : www.blagdonpump.com  
E-Mail : sales@blagdonpump.com