

Service / Maintenance Log		
Date	Details	Completed

Contact Information	
Contact	Phone / Fax No.

# MANUAL AND PARTS LIST



**AP50**  
**SUBMERSIBLE**  
**CENTRIFUGAL PUMP**

DISTRIBUTOR

**IMPORTANT**

This pump should be used in accordance with the requirements of the Safety, Health & Welfare at Work Act 2005. All business conducted subject to IDEX Pump Technologies, Ireland. Terms and Conditions of Sale, available on request.



**BLAGDON PUMP**

IDEX Pump Technologies (Ireland) Ltd.,  
 A Unit of IDEX Corporation,  
 R79, Shannon, Co Clare, IRELAND.  
 TEL : +353 61 471933 FAX : +353 61 475046  
 Web Site : [www.blagdonpump.com](http://www.blagdonpump.com)  
 E-Mail : [sales@blagdonpump.com](mailto:sales@blagdonpump.com)

**AP50**  
**AIR POWERED CENTRIFUGAL PUMP**

**1. OPERATION**

1.1 Check level of oil in reservoir by removing oil filler plug (36). An SAE 20 mineral based oil or equivalent is recommended.

**Caution**

Care should be taken when working with oils & greases, they should be handled in accordance with good standards of industrial hygiene and safety practices. Use a barrier cream, wear pvc or neoprene gloves and overalls. Regular changes of contaminated clothing is recommended.

1.2 Ensure that all air connections to the pump are clean and secure. Turn on air supply to check free starting of the pump prior to submergence in the fluid. Maximum air pressure - 8.6 Bar (125 psi). A filter / regulator located in the air supply line is recommended.

1.3 If the pump fails to start immediately, the rotor vanes (55) may be sticking, turn air supply on & off full bore repeatedly, to free the vanes.

1.4 Should the pump still fail to run, turn off the air supply and remove the base strainer (1). Turn the impeller (3) by hand to ensure free rotation, remove solids accumulation where necessary. Refit base strainer.

1.5 Ensure air filter (39), located in air hose union (40) is clean. Blow air through exhaust outlet thereby reversing the air flow, which in turn should remove any contamination. Alternatively, remove air hose union (40) and manually clean the filter.

1.6 When operating the pump fully submerged, a hose should be fitted to vent the exhaust air to atmosphere.

**2. LUBRICATION**

2.1 Check oil level daily or after 8 hours of continuous use. The rate of oil flow is set prior to despatch from the factory. Adjustment can be made to the oil flow if necessary. Remove the lock screw (26) to gain access to the oil feed screw (25). Turn the oil feed screw (25) clockwise to restrict oil flow and anti-clockwise to

**TECHNICAL DATA**

Max. Delivery : 34 M<sup>3</sup>/hr (125 psi)

Max. Working Pressure : 8.6 bar (125 psi)

Max. Solid Particle Size : 6mm

Air Inlet : 3/4" BSP(M)

Exhaust Outlet : 1" BSP(F)

Fluid Outlet : 2" BSPT(F)

Feed Method : Submerged

Weights :-

Pump : 32.0 Kg

Shipping (Boxed) : 33.0 Kg

Dimensions :-

Boxed : 500 x 380 x 260

**PERFORMANCE CURVE**

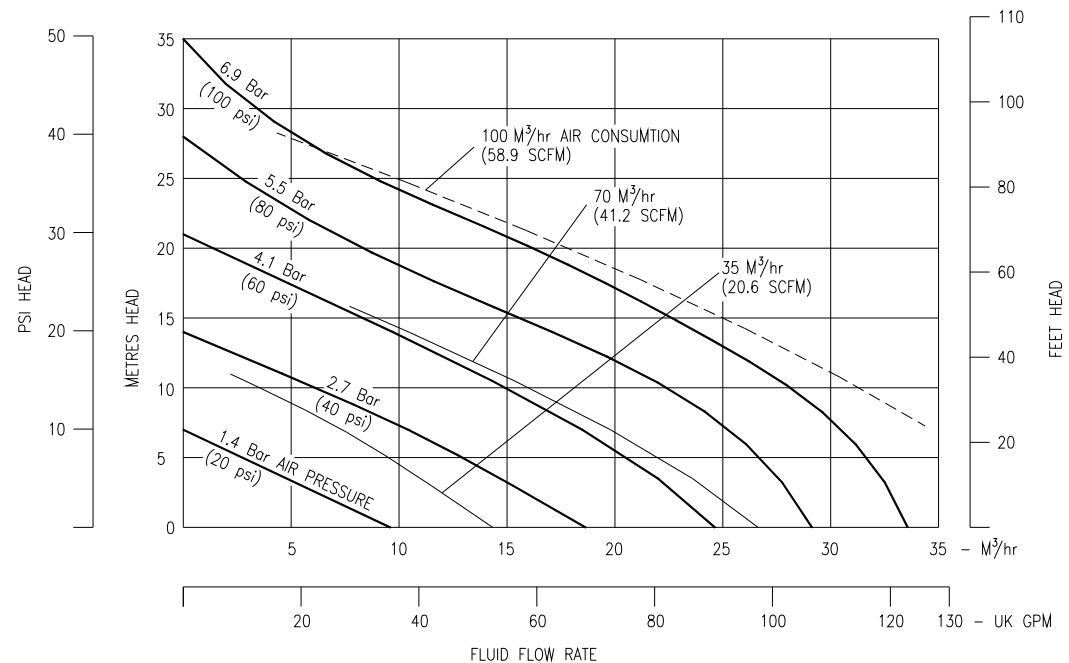

## DIMENSIONS

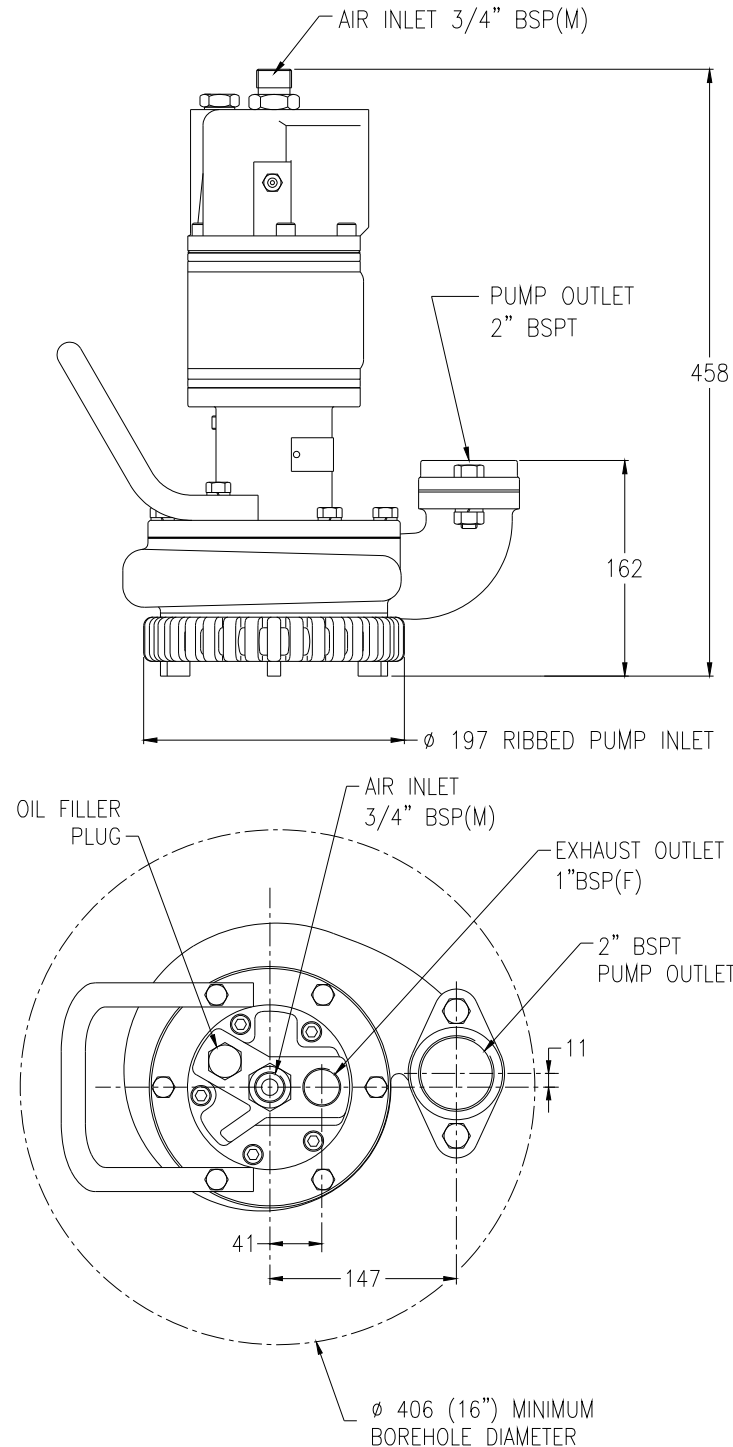

increase oil flow. Replace lockscrew (26) to protect oil feed screw from damage.

- 2.2 There are two grease lubrication points on the pump, both use a Castrolase CL Light, or equivalent grease. The upper grease nipple (67) only requires one push of the grease gun per month to lubricate the governor mechanism. The lower grease nipple, supplying the lower pump bearings and pump seals may be generously filled. Remove the level plug (65) and pump grease into the grease nipple (67) until it shows at the level plug aperture. Replace level plug (65). Check levels regularly & ensure correct grease is used. Failure to use correct grease may result in premature seal and bearing failure.

NOTE - When operating the pump the following guidelines should be observed to ensure low maintenance.

- 2.3 Pumping solids increases wear, it is therefore advisable to arrange for the pump to stand on a firm base to prevent sinking.
- 2.4 When pumping abrasive solids and matter in suspension, the impeller (3) clearance should be increased by adding more gaskets (4) & (5) to act as shims at the flange joint.
- 2.5 Do not operate the pump for long periods out of the fluid as the frictional heat generated may damage the seals and bearings.
- 2.6 The noise generated by the pump in confined spaces may be objectionable, a silencer (part no. AP50.79), is available to reduce noise levels to an acceptable level.
- 2.7 When it is necessary to completely de-water tanks, bilges etc., a perforated base plate (part no. AP50.78), is available and should be fitted as an alternative to the standard strainer (1).

### 3. OVERHAUL / REPAIR

NOTE - Ensure air supply is dis-connected before attempting to overhaul any section of the pump.

#### Governor Housing

- 3.1 Remove cylinder bolts (51) from pump assembly. Lift the governor housing (50) free from the pump assembly together with air hose union assembly.

- 3.2 Check freedom of movement of the upper governor section (48) together with governor balls (31) & ball cage (30). Check for wear or damage and replace as required.
- 3.3 Ensure that governor valve (45) is free by pushing against the spring (44). If excessive wear is suspected, remove air hose union (40) and withdraw governor valve. Check both valve (45) and cylinder (34) bore for wear or damage and replace as required. If o-rings (35) & (46) are damaged or attacked, replace as required.
- 3.4 Re-assemble the governor housing as above in reverse order. If gasket (53) is damaged or soiled, replace prior to final assembly. Ensure that an adequate supply of grease is pumped into the housing via the grease nipple (67) prior to pump running.

#### Air Motor

- 3.5 Remove the governor housing as described above. Lift the air motor assembly free from the pump, and place in a clean area.

#### **Caution**

In the event of the pump running without any lubrication, Rotor Vane wear debris may be present within the air motor section. Dust masks should be worn to prevent the inhalation of particles.

Using the cylinder bolts (51), screw into the upper bearing plate (27) and 'jack' the plate off the cylinder body (20).

- 3.6 Check the rotor vanes (55) for excessive wear and replace as required. Ensure that the springs (54) are correctly positioned prior to re-assembly.
- 3.7 Both upper and lower bearings should turn freely, if difficulty is experienced, replace immediately. Ensure all components are clean prior to re-assembly.
- 3.8 Re-assemble the air motor as described above in reverse order. If gasket (61) is damaged or soiled, replace prior to final assembly. Ensure the slots of the coupling nut (63) are correctly engaged in the impeller shaft (74) before fully tightening of the cylinder bolts (51).

## PARTS LIST

REF No	PART No.	DESCRIPTION	MATERIAL	QTY
1	AP50.60	STRAINER	S.G. IRON	1
2	AP50.55	VOLUTE	CAST IRON	1
3	AP50.57	IMPELLER	GUNMETAL	1
4	AP50.56	VOLUTE SHIM (0.010")	PLASTIC	A/R
5	AP50.56A	VOLUTE SHIM (0.015")	PLASTIC	A/R
6	AP50.52	SEAL	NBR/ST.STEEL	2
7	A135	HEX. HEAD BOLT - M10 x 25	HT. STEEL	4
8	AP50.51	BEARING HOUSING	CAST IRON	1
9	AP50.43	BUSH	MANGANESE BRONZE	1
10	AP50.42	BEARING NUT	STEEL PLATED	1
11	AP50.41	BEARING	STAINLESS STEEL	1
12	AP50.80	NAMEPLATE	BRASS	1
13	K076	HAMMERDRIVE SCREW - No6 x 3/16	STEEL PLATED	2
14	AP50.67	HANDLE	M.S. TUBE	1
15	A063	HEX. HEAD BOLT - M10 x 40	HT. STEEL	2
16	AP50.44	INTERMEDIATE SECTION	CAST IRON	1
17	AP50.33	LOWER BEARING PLATE	GUNMETAL	1
18	AP50.20A	DOWEL	HT. STEEL	4
19	AP50.25A	LOCATING SCREW	HT. STEEL	1
20	AP50.20	CYLINDER BODY	S.G. IRON	1
21	AP50.25	CYLINDER LINER	CAST IRON	1
22	AP50.29	ROTOR SHAFT	HT. STEEL	1
23	AP50.28	ROTOR KEY	KEY STEEL	1
24	AP50.13	FELT PLUG	FELT	1
25	AP50.15	ADJUSTING SCREW	HT. STEEL	1
26	AP50.09	LOCKSCREW	HT. STEEL	1
27	AP50.22	UPPER BEARING PLATE	GUNMETAL	1
28	AP50.23	CIRCLIP	HT. STEEL	1
29	AP50.19	LOWER GOVENOR SECTION	STEEL	1
30	AP50.18	BALL CAGE	ACETAL	1
31	AP50.17	GOVENOR BALL	STEEL	2
32	AP50.72	THRUST PAD	STEEL	1
33	AP50.07A	GOVENOR VALVE BALL	CARBIDE STEEL	1
34	AP50.04	GOVENOR CYLINDER	BRASS	1
35	AP50.05	O-RING	NITRILE	1
36	AP50.11	OIL FILLER PLUG	STEEL	1
37	AP50.12	WASHER	FIBRE	1
38	AP50.03	SPRING SPIGOT	BRASS	1
39	AP50.02	AIR FILTER	STAINLESS STEEL	1
40	AP50.01	HOSE UNION	STEEL	1
41	Z128	BLANKING PLUG	PVC	1

## Pump Body

- 3.9 Remove governor housing and air motor as previously described. Remove bolts (7) from volute (2) and lift pump body assembly free.
- 3.10 Turn pump body over, lock impeller and remove nut (81) together with impeller (3) from intermediate section (16).
- 3.11 Remove bolts (76) and withdraw bearing housing assembly (8) from intermediate section (16).
- 3.12 Turn impeller shaft (74) and check for ease of movement and quality of impeller bearing (11). Replace bearings as required.
- 3.13 To replace bearing (11), remove circlip (7) and withdraw impeller shaft (74) from housing (8). Unscrew impeller nut (10) and withdraw bearing (11).
- 3.14 Check impeller seals (75) and o-ring (6) for wear or damage, replace as required. Ensure correct position of seals (75) so that lips face the impeller.
- 3.15 If impeller is damaged or excessively worn, performance of the pump will be reduced. When replacing, the impeller must be adjusted to within 0.005" to 0.010" from the volute (2) internal face for maximum efficiency. This is achieved by the addition or subtraction of shims (4) & (5).
- 3.16 Re-assemble the pump as described above in reverse order. Ensure all fittings are tight and secure before running the pump.

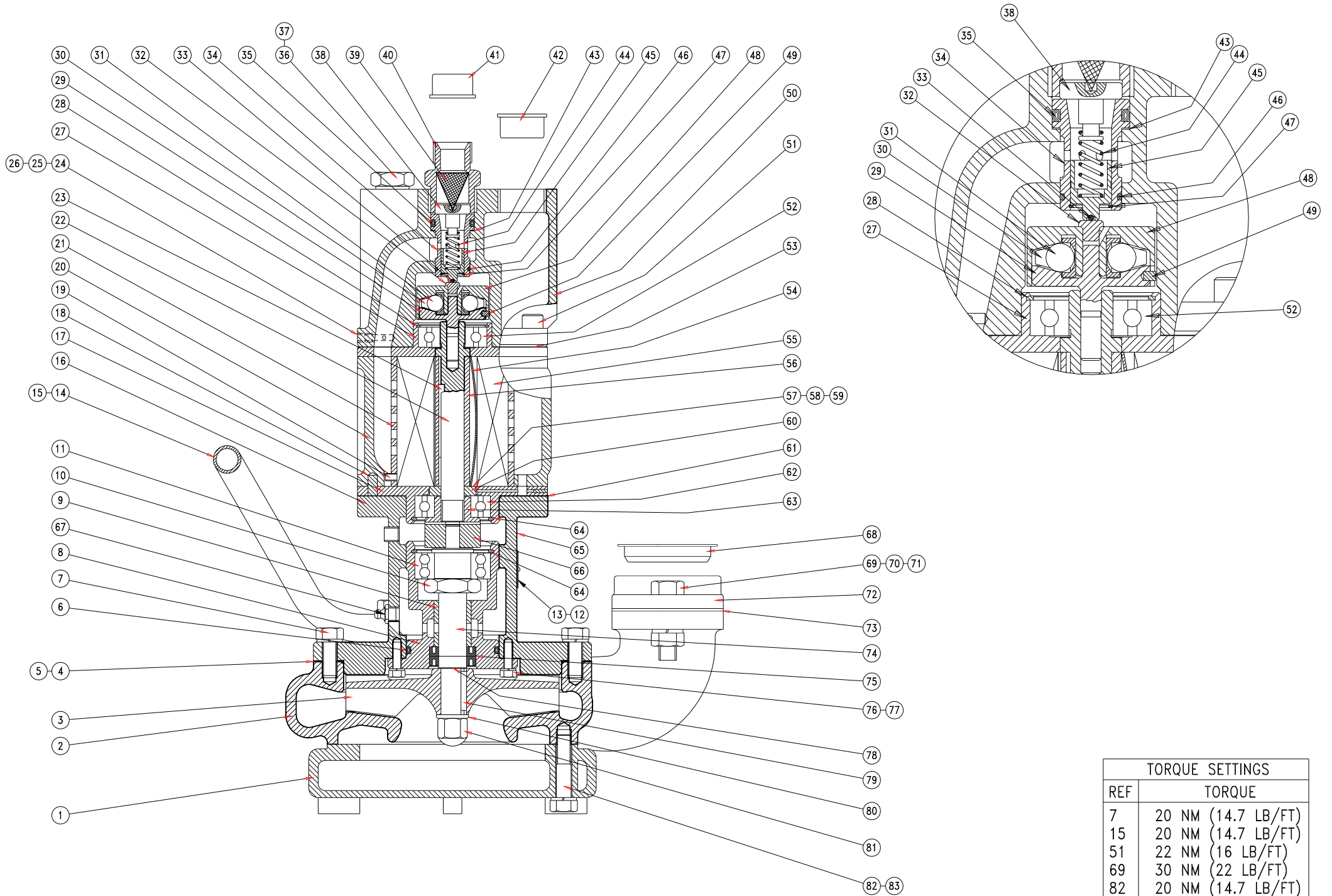

TORQUE SETTINGS	
REF	TORQUE
7	20 NM (14.7 LB/FT)
15	20 NM (14.7 LB/FT)
51	22 NM (16 LB/FT)
69	30 NM (22 LB/FT)
82	20 NM (14.7 LB/FT)